

# Contact Sheet

Journal of the Eastern Idaho Photographic Society  
Vol. 20, No. 11

November 2008

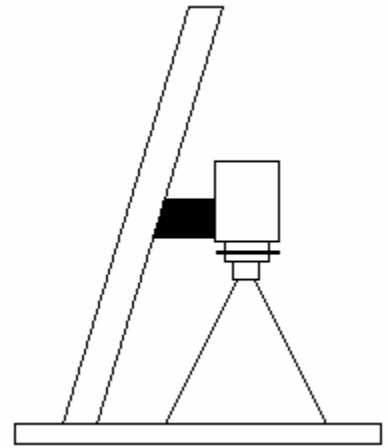

## Number 20 Was a Good One

Thanks to all of your efforts and the people who entered our juried show, we had a very good exhibition for our **20<sup>th</sup> Annual Juried Show and Sale at the Eastern Idaho Technical College**. There is a lot of effort by many people to get an excellent show such as this effort. We have always felt that the juried show is one of the best learning tools to improve in your photographic skills. You take a picture that you like. Your friends and spouse all say that it is really extraordinary. But, is it? Most of us do not get to count Ansel Adams as a close friend to call and evaluate our efforts. And if we did have him as a friend, we would be afraid to ask! As difficult as it is to a photographer's fragile psyche, we improve when we show our efforts to impartial judges. They can point out what we need to improve to get a better image, what they like about the shot, what they do not like. If our spouse said some of those things, we might not speak to them for a week or two - - or even longer!

We had an extremely good panel of judges at this year's show. **Leland Howard**, a local landscape photographer who has had several of his photography books published for nationwide distribution, has judged our show in the past and was kind enough to share his thoughts with us. **Paul Cartwright** is a commercial photographer who currently manages Inkley's photography studio. And **Kristi Sheriff** is a local wedding/portrait photographer with her own studio. Therefore, we had three major areas of photography covered for our participants in this year's show. Our club treats the judges to dinner before the show, but this can be only a small token for the true gratitude we must feel for their efforts. Thanks, again.

Our club awarded over \$1200 in cash and prizes to this year's participants, thanks to our generous sponsors who are as follows:

**Farr's Jewelry**  
**Gallery Photo Lab**  
**All Seasons Anglers**  
**Randi Kirchofner**  
**Defining Line Salon**  
**D&D Hitech Auto Clinic**  
**Happy's Chinese Restaurant**  
**Willowtree Gallery**  
**The Framing Corner**  
**Sam's Club**  
**Queen Studio**  
**Lily's Consignments**  
**Jalisco Restaurant**  
**Musicare**  
**Shari's**  
**Lyn's**  
**London Café**  
**Lily's Too**  
**Jaker's**  
**Garcia's**  
**Johnny Carino's**  
**The Firehouse Grill**  
**Ferrells**  
**Iggy's**  
**Plum Loco**  
**Pandora's Beads**  
**Inkley's**  
**Great Harvest Bread**  
**Chesbros**

**Congratulations to all who entered our show since you made this our best effort to date! And the winners are (Best of show and the next three places receive cash awards from the club):**

**Best of Show: Chris Leavell, *February Moon***  
**First Place: Jan Larcom, *Fall's Full House***  
**Second Place: Curt Papke, *Frosty Morn***  
**Third Place: Jan Larcom, *Sheltered Barn***  
**Fourth Place: Ramona Murdock, *Companions***  
**Fifth Place: Sue Heng, *Snowy Playground on the Gibbon***

## Club Notes

Special thanks to Farr's Jewelry for the use of the digital projector at the last Advancement Program. We learned a lot!

Please start thinking about nominations for club officers for next year. Please help your club by being an officer. Most of the positions only will take a small amount of your time but the club will continue to improve with your help. **A club is only as strong as the sum of its members.**

We had a good turnout for our inclusion in the citywide gallery tour on October 2 in the evening. About 30 community members came by EITC to look at our images. These would be people that may not have ever even thought about seeing a local photography show without our inclusion in the tour. Most of the people that I saw while I was there spent a lot of time looking at the various images – which I felt was a good sign. I think they truly enjoyed looking at our art. We would have been the only photography exhibit they would have seen that evening since most of the other galleries would be emphasizing paintings and sculpture.

## Advancement Program

The theme of the Advancement Program for November is: **Barns**. Please bring three of your best images, slides, digital image files and join us at 1900 Grandview in the Conference Room at 7:30 p.m. on November 20. It is amazing how all of our photography improves as we share these images with one another.

I apologize for the small eight font size on the next portion of the newsletter, but I wanted to include all entrants in the show.

## Monthly Meeting

**Date: Nov. 6, 2007**

**Time: 7:30 p.m.**

**Location: 1900 Grandview Ave. Conference Room**

### Program:

We will be getting an update on the **World of Photography** by the manager of **Farr's Jewelry** at this month's meeting. We live in exciting times in our field with an explosion of technology.

**Chris Leavell – President**  
**e-mail address: [cleavell@fretel.com](mailto:cleavell@fretel.com)**  
**Membership Info:**  
**Web address: [www.eips.net](http://www.eips.net)**

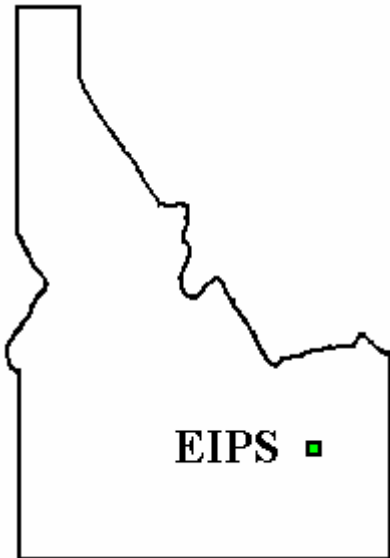

## Graffiti

Also, We have a very unique prize of an oil painting done by **Les Stimpson** of the **Eagle Rock Art Guild**. We thought this would be an excellent People's Choice award and asked those who came to our Art Walk Open house to vote on their personal Best of Show. Results were very interesting in that we had 10 images receive one vote and five others receive two votes. Therefore, we have asked the Administration at EITC to help with their submissions for the best image presently in their hallways.

**FIELD TRIP to Ashton area for old barns, buildings, houses, old schools on November 8. Keep posted on our web site in case of weather problems.**

