

Contact Sheet

Journal of the Eastern Idaho Photographic Society
Vol. 20, No. 9

September 2008

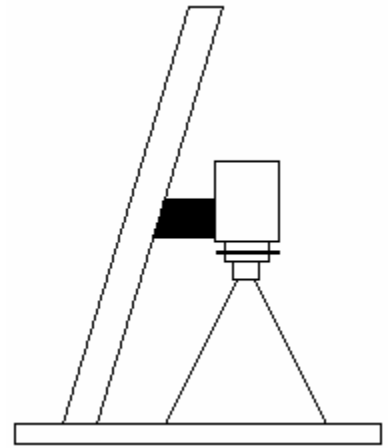

Eating and Photography

The August meeting of the Eastern Idaho Photographic Society was our social event of the year, our annual club picnic. This is the one time of the year when we get to meet the long-suffering spouses who have to put up with our numerous idiosyncrasies as we wander the world hunting for that perfect award-winning image. And photographers tend to be an odd lot. We like very specific types of cameras, very specific types of media or film, etc. and we will argue to the end of the earth why our choices are the best ones. We are bear photographers, scenic photographers, people photographers, and all sorts of different anomalies. Sometimes we don't know what type of images we want to shoot, but we are willing to travel about anywhere at anytime to get **“that special image”**. And the spouse knows that look in the eye that means the photographer is into their own world - - again. **They are in the zone! Nothing is going to stop him/her from getting the perfect shot this time.** Once this trance-like state passes, the photographer will return to the real world, become a husband/wife to the spouse again and approach **some** semblance of normal – for a short while. Sometimes the only sanity in the relationship happens when the spouse takes up photography too. Then you have two odd people in the household

with no real normal people around – and they are happy since the balance check of what is truly normal has disappeared!

The club picnic this year was a fun group of people discussing a wide range of topics, but somehow, photographic subjects seemed to be in the background. Where on the Internet do you find moonrise information so that I can get images of moonrises over the Tetons? When can I take star trail pictures without moon interference? Where can I get the bear pictures in Yellowstone? Have you tried wolf pictures? What happened to the barn that was at such and such place? Where are you going on your vacation this year (Yes, I know that this sounds like a normal person question; but coming from a photographer's mouth, you know the next bit of information will be what subjects they are going to photograph!).

The rain that came down that night happened exactly after the last person finished the last bite on their plate, and started with a few drops of really hard rain. While everyone grabbed a food dish, etc. and moved everything in doors, the rain totally stopped. Once the deck was cleared, the rain began in earnest; and the conversations resumed in a nice dry environment as the rain pelted the deck and patio. As the host of the party, I appreciated the rain since this saved me several trips into the house carrying all of the items from the deck. We all had a

good time and learned a lot about different people – oh, and also, a lot about photography!

Club Notes

Thanks to all people who participated in the Show and Sale at the Duck Races. It was a good way of showing our community what types of photographic images are taken by our local photographers. Thanks to all who helped with the setup and takedown of the various booths since this can be a very laborious task when done by just one or two people.

I do not have a list of club members who have items on show at the Eastern Idaho State Fair in Blackfoot, but make an effort to attend the display. There are always some very special images that turn up at the show. Maybe this will inspire you to get some images in the fair next year. We all know you can do it!

Special thanks to Farr's Jewelry for the use of the digital projector at the last Advancement Program. This makes our learning much more enjoyable!

There was an extended discussion about the categories that we would have in our October EIPS Juried Show at the last meeting. There has been a gradual decline in the B&W category so that they only comprise about 20% of the entries. We have been careful to only give 20% of the prizes to this group. But considering that most of the B&W are really taken now with a digital color camera and then just converted into B&W in PhotoShop, we

felt that this was just another form of digital manipulation and should not be rewarded any differently than a distortion filter, alteration of color filter, etc. Therefore, we are eliminating the individual category of B&W. They can still be entered in the show as in the past, but will not be in their own niche. We will add a paid third and fourth place with Honorable Mentions getting the various prizes that we are able to collect.

We need people to help get the show prizes, help with the open house and the Art Walk sponsored by the Art Council. Please help with these efforts since you benefit from these club efforts!

You will note that we have moved the date of the show up one week so that we can be part of the Art Walk, just as we did last year. We had a very good turnout of visitors to our show on that night. And this gives our club a photography a good boost to show the quality of images produced in this community. Please continue to enter your images in the show. We know your photos are good. Let the community see your efforts!

Advancement Program

The theme of the Advancement Program for September is: **Long Shutter. Remember the Field Trip to the July 4th Fireworks? This would be a beautiful time to share your images with various club members.** Please bring three of your best images, slides, digital image files and join us at 1900 Grandview in the Conference Room at 7:30 p.m. on September 18. It is amazing how your – and our – photography improves as we share these images with one another.

Monthly Meeting

Date: Sept 4, 2008

Time: 7:30 p.m.

Location: 1900 Grandview Ave – conference room

Program:

One of the founders of EIPS moved to Kentucky a few years ago. **Jim Waller** had polio when young leaving him in a wheel chair, but never thwarted his love of photography. See Kentucky in the fall from his perspective in his slide show.

Chris Leavell – President
e-mail address: cleavell@fretel.com
Membership Info:
Web address: www.eips.net

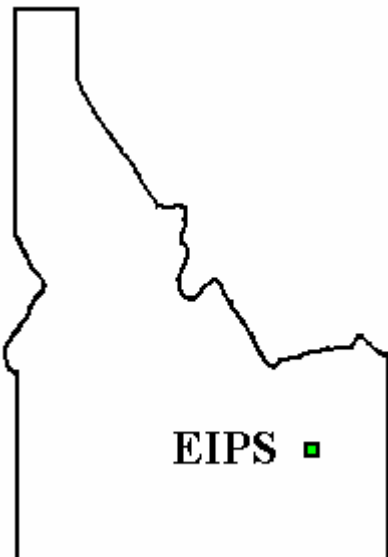

Graffiti

EIPS is a group of amateur and professional photographers who have joined together to further the art and craft of photography. Please join us and expand your horizons. Sharing knowledge makes all participants better at their craft. We meet on the first Thursday of each month for our educational lecture. Then the third Thursday is our Advancement Program where we share some of the images we have done. We meet at 7:30 p.m. in the 1900 Grandview Ave conference room. We all become better photographers!

If you can't make the Advancement Program, e-mail your images to Roger and he will include them in our Advancement Program!

